



CRUISER Series

Vertical Machining Center

MAXMILL Since 1960

Maxmill Machinery CO., Ltd.

No.90, Alley 189, Wuguang Rd., Wuri District,
Taichung City 41470, Taiwan
Tel: +886-4-2338 8879 Fax: +886-4-2336 1750
E-mail: sales@maxmill-cnc.com.tw
<http://www.maxmill-cnc.com>
September 2015E



IT'S VERY WELL
MADE IN TAIWAN **CE ISO 9001**

All specifications are subject to change without prior notice.





CRUISER Series

Vertical Machining Center

MAXMILL Since 1960
Maxmill Machinery CO., Ltd.



IT'S VERY WELL
MADE IN TAIWAN

CE ISO 9001

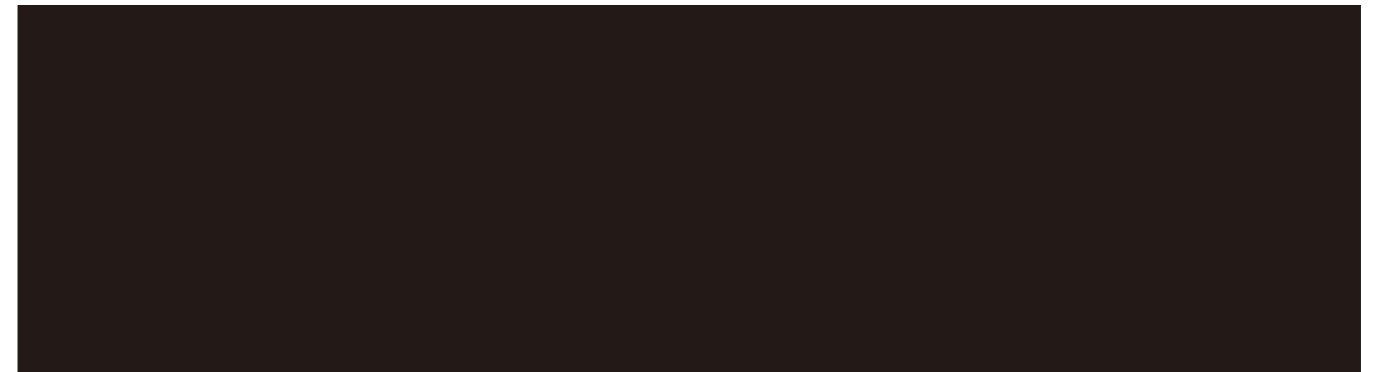

Cruiser is all you can rely on for taking your business to higher levels of productivity.

VMC - 855 / 966
NVM - 1166
VMC - 1270 / 1470



VMC- 855



VMC- 966

The massive and strong construction provides a solid grounding for superior machining performance.

The **CRUISER series** achieves difficult tasks with ease and efficiency, and far beyond your expectations!

FEATURES

- Box ways are extremely hardened and precisely grounded, and then coated with high quality low friction Turcite-B for maximum wear resistance. The mating surface are precision treated for long term accuracy.
- The pyramid machine construction features a perfect structural ratio. The major casting parts are scientifically rib reinforced, ensuring high accuracy for various machining applications. This outstanding machine construction effectively extends service life and features stable thermal effect and added dampening effect.
- When installing 3 axes ball screws, ball-bar testing and laser equipment are employed for parameter adjustment to achieve the best possible accuracy.
- Optimized machine construction. The major machine parts, such as base, column and saddle, etc., are manufactured from high quality alloy cast iron. It features maximum stability, minimum deformation and lifetime reliability.
- VMC-1270/1470 is constructed of a vast machine bed with four box ways on Y-axis, which combined with gibs provided at inner sides providing outstanding stability when cross movements, and everlasting cutting performance reliability

VMC- 1270
VMC- 1470



A Perfect Arch Structure

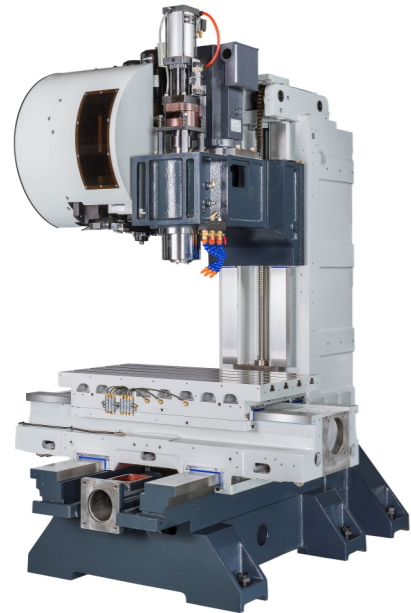

VMC-855



NVM-1166



VMC-1270 / 1470



NVM-1166



■ Bulkheading of machine base will greatly reduce the possibility of leaking occurs.

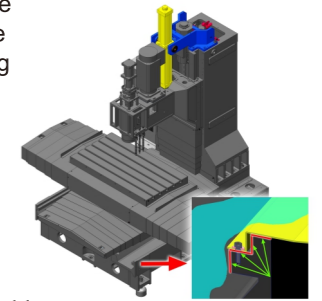

■ The base of machine is 4 box guideways. Moreover, the chip groove and base are integrally molded, which provides the maximum support span and rigid construction.

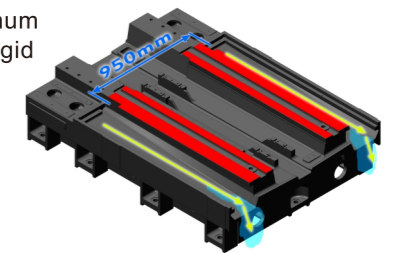

■ The support of both column and tool magazine, which corresponding with various options regarding tool specifications and capacity.

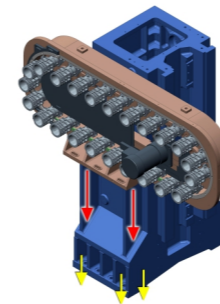

■ Spindle head is equipped with pneumatic counterweight, which will greatly reduce the inertial force that generates from traditional counterweight during the rapid traverse rate of feed on Z axis, and perform the perfect cutting accuracy and efficiency.

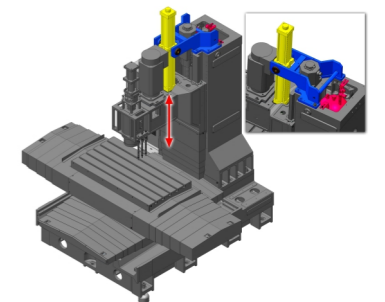

■ Working table is designed as emission-rib type, not only reinforced the rigidity of working table but also avoid the deformation caused by clamping the working piece.

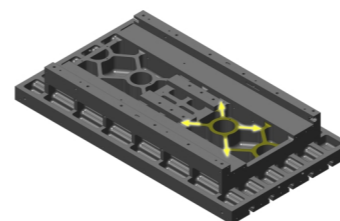

■ Widen the interface of column bottom to 880mm, and applied with X-type cross-rib design, which will improve the anti-torsion rigidity of the column.

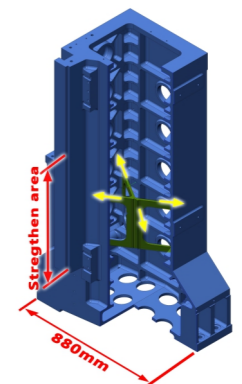

Extremely Fine Craftsmanship

Based on the tradition of precision manufacturing capabilities, outstanding scraping techniques and with attention to every detail, results in extremely smooth slideways and precise mating surfaces. Also, the fine craftsmanship upgrades machining accuracy, rigidity and ensures lifetime reliability.

Dimensional Drawings

VMC - 855

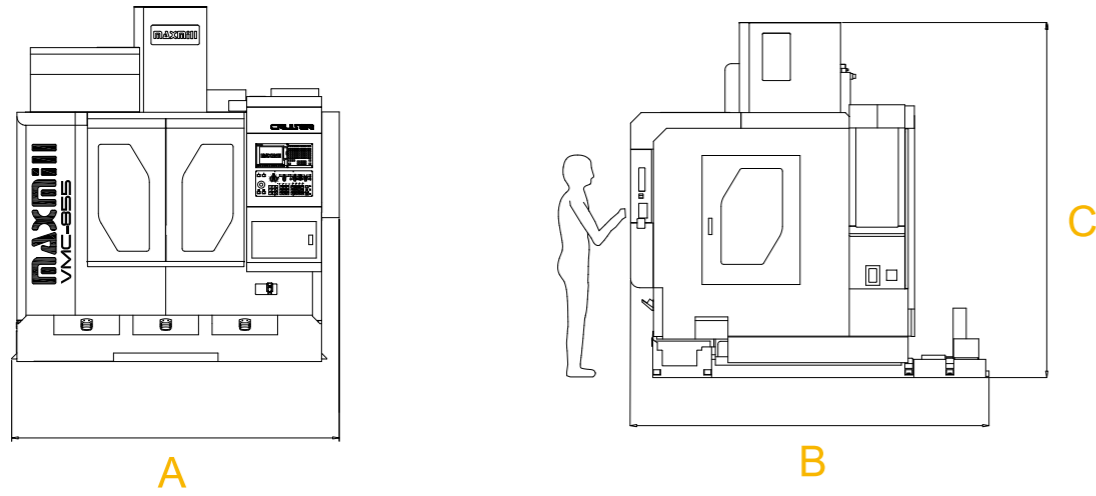

VMC - 966

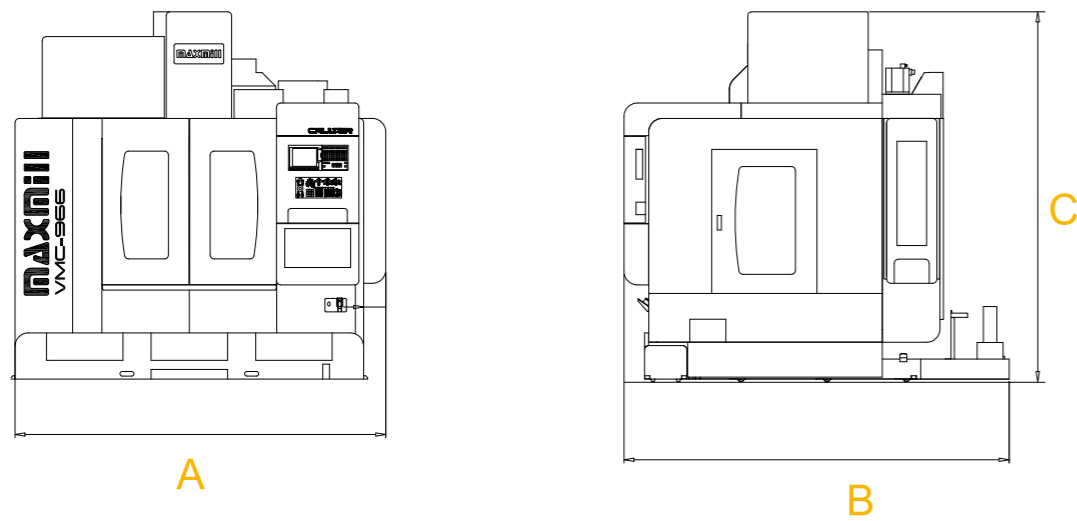

NVM - 1166

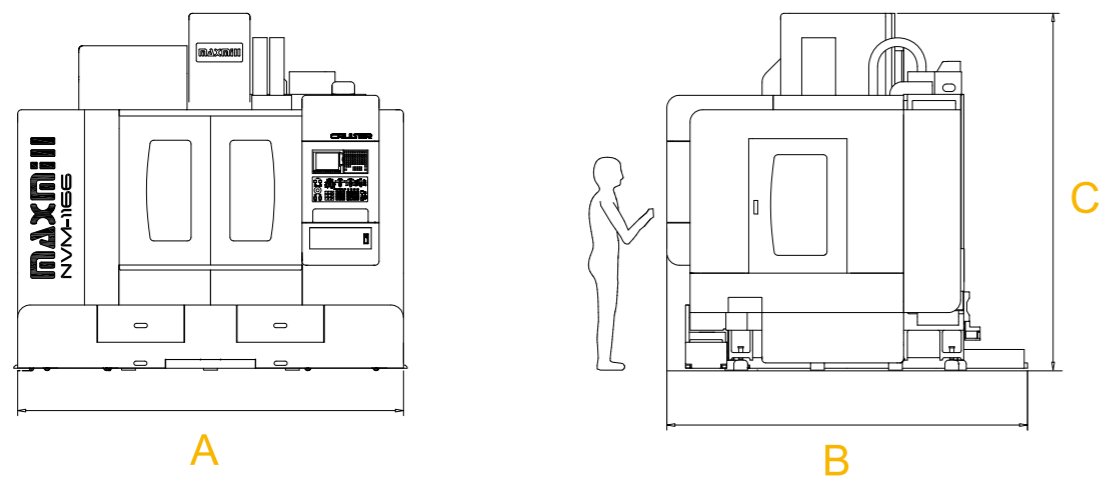

VMC - 1270

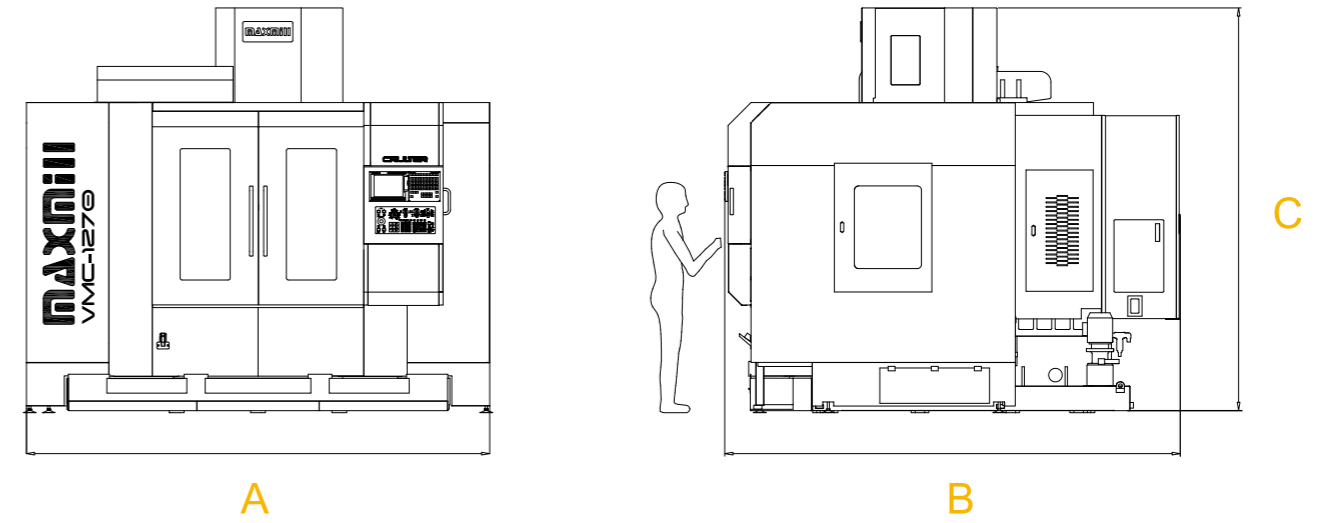

VMC - 1470

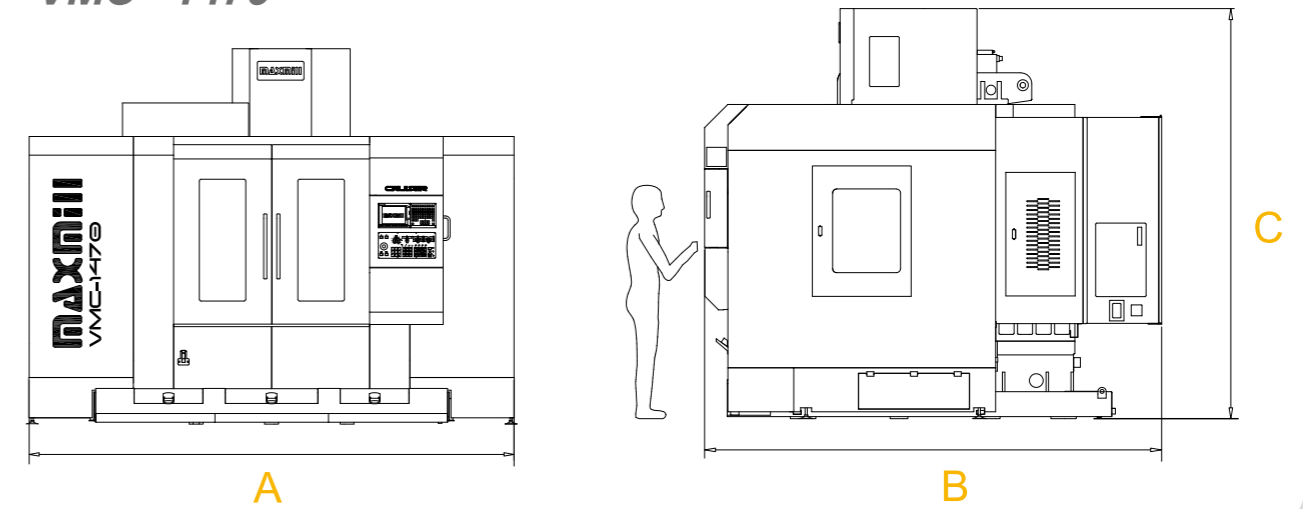

unit:mm

MODLE	A	B	C
VMC-855	2508	2745	2720
VMC-966	2795	2875	2700
NVM-1166	3140	2880	2850
VMC-1270	3418	3380	2920(BT40) 3030(BT50)
VMC-1470	3858	3380	2920(BT40) 3030(BT50)

Belt Driven Spindle System (Standard)

- The spindle head has coolant circulation system. The circulated cooling system effectively reduce the heat generated from spindle and gears, while performing heavy cutting or high speed cutting. The cooling system avoids spindle deformation due to over heating and avoids affecting machining accuracy due to the spindle center offset, while ensuring long service life of the spindle bearings.
- Tool catching system has a steel ball to hold the tool shank firmly.
- Spiral circulated grooves on the spindle sleeve, incorporated with spindle oil cooler system as standard efficiently remove the generating temperature providing the best solution on spindle accuracy for long term operation.



Direct Driven Spindle System (Optional)

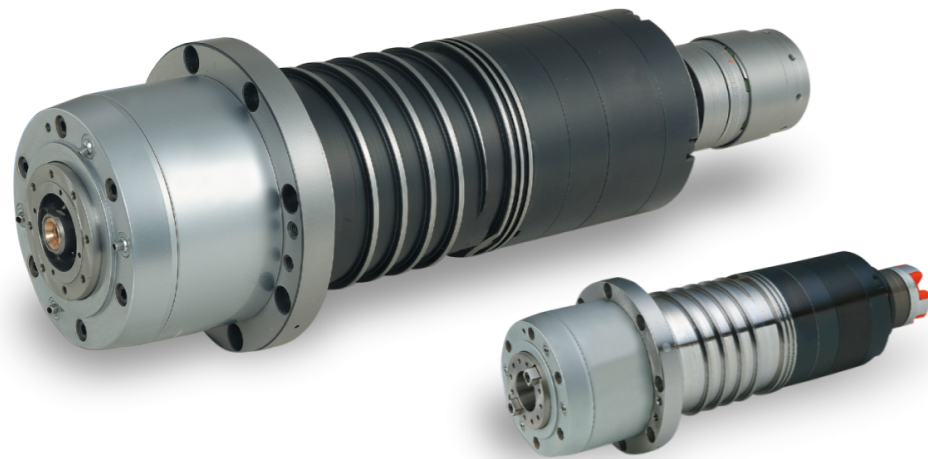

- The spindle and drive motor are connected co-axially by a diaphragm coupling to achieve high-precision rotation of the spindle throughout its entire speed range.
- Even at full capacity, the spindle achieves high-precision machining conditions, such as varied directional cutting resistance machining, high helix angle end mill machining and back face machining.

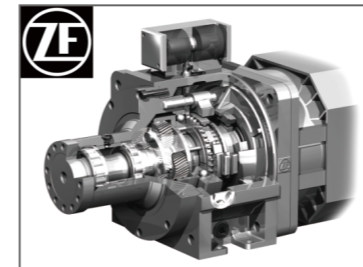

German ZF 2-speed gear box, provide maximum cutting ability in low speed.

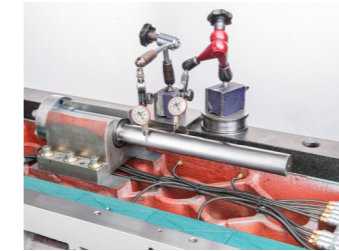

Direct driven and pretension design of Ball Screw $\varnothing 40$ ($\varnothing 50$ V12/14) in Grade C3 can eliminate noise whole transmission, drop in temperature, stability accuracy and increase rigidity of machine.

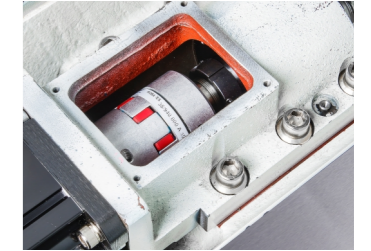

Various CNC Controllers



MITUSBISHI M70 / M720 / M730



FANUC Oi-MF/31i-MB



SIEMENS 828D/840D

Chip Conveyor (optional)

During machining, chips are flushed into the chip auger, then delivered to chip tray. This ensures a cleaner working area at all time. Please choose the most suitable chip conveyor accordance to your machining chip scenario.

Chip type	Curly Iron Chip	Metallic Chip	Non-Curly Chip	Curly Aluminum Chip	Aluminum Chip	Non-Metallic Chip
Conveyor type						
Link type	⊙	⊙	⊙	⊙	⊙	⊙
Screw type		⊙	⊙		⊙	⊙
Scraper type			⊙	⊙	⊙	⊙
Vanes type		⊙	⊙		⊙	⊙

⊙ Best efficiency ⊙ Above average efficiency ⊙ Other possible choices

Quality & Inspection

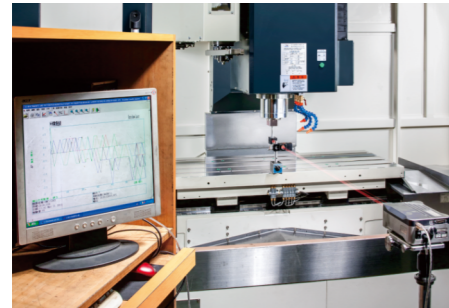

Measurement by Laser

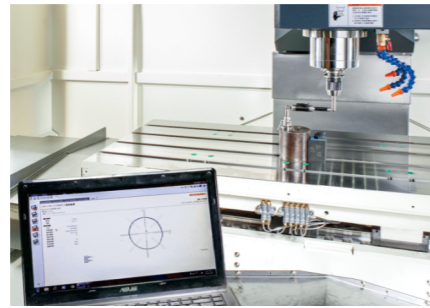

Measurement by Ball-bar

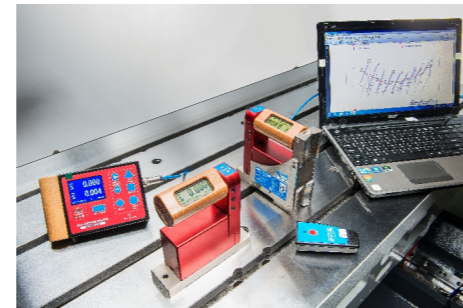

Measurement of accuracy



Measurement of accuracy

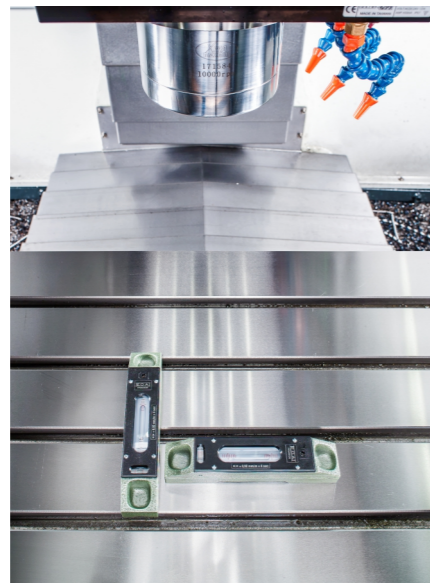

Measurement of accuracy

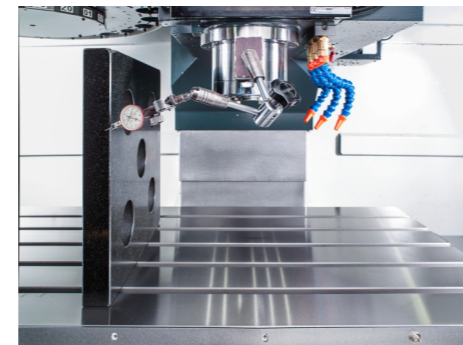

Measurement of accuracy



Measurement of accuracy



Measurement of inspection for hardness



Measurement of inspection by 2D coordinate 2D

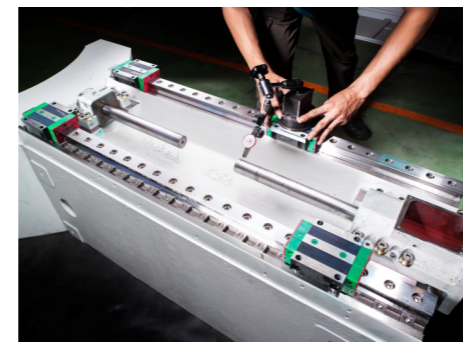

Measurement of parallelism and concentricity

Machine Specifications

Model	Unit	VMC-855	VMC-966	NVM-1166	VMC-1270	VMC-1470	
TRAVEL	X axis	mm(inch)	800(31.5)	900(35.4)	1,150(45.3)	1,200(47.3)	1,400(55.2)
	Y axis	mm(inch)	500(19.7)	650(25.6)	670(26.4)	700(27.6)	700(27.6)
	Z axis	mm(inch)	520(20.5)	600(23.7)	600(23.7)	600(23.7)(BT-40) 630(24.8)(BT-50)	600(23.7)(BT-40) 630(24.8)(BT-50)
	Spindle nose to table	mm(inch)	100-620 (4.0-24.5)	120-720 (4.8-28.4)	100-700 (4.0-27.6)	130-730(5.2-28.7)(BT-40) 130-760(5.2-30.0)(BT-50)	130-730(5.2-28.7)(BT-40) 130-760(5.2-30.0)(BT-50)
	Spindle center to solid column surface	mm(inch)	550(21.7)	701(27.6)	720(28.4)	780(30.7)	780(30.7)
TABLE	Working area	mm(inch)	950 x 460(37.5 x 18.2)	1,100 x 600(43.3 x 23.7)	1,300 x 600(51.2 x 23.7)	1,350 x 650(53.2 x 25.6)	1,550 x 650(61.0 x 25.6)
	Max. loading	kg	500	1,000	1,200	1,200	1,400
	T-Slots (No. x Width x Pitch)	mm(inch)	4 x 18 x 100(4 x 0.7 x 4.0)	5 x 18 x 100(5 x 0.7 x 4.0)	5 x 18 x 100(5 x 0.7 x 4.0)	5 x 18 x 125(5 x 0.7 x 5.0)	5 x 18 x 125(5 x 0.7 x 5.0)
SPINDLE	Tool shank	-	BT-40	BT-40	BT-40	BT-40(BT-50)	BT-40(BT-50)
	Speed	rpm	10,000	10,000	10,000	8,000(6,000)	8,000(6,000)
	Transmission	-	Direct-Speed Belt Drive	Direct-Speed Belt Drive	Direct-Speed Belt Drive	Direct-Speed Belt Drive	Direct-Speed Belt Drive
	Bearing lubrication	-	Grease	Grease	Grease	Grease	Grease
	Cooling system	-	Oil cooled	Oil cooled	Oil cooled	Oil cooled	Oil cooled
	Spindle motor max. rating	kw(HP)	7.5(10)	11(15)	11(15)	15(20)	15(20)
	Axis motor max. rating (MITSUBISHI)	kw	1.5 / 2.0 / 1.5	2.0 / 3.5 / 2.0	2.0 / 3.5 / 3.5	3.5 / 3.5 / 3.5	3.5 / 3.5 / 3.5
Axis motor max. rating (FANUC α)	kw	1.6 / 1.6 / 1.6	3.0 / 3.0 / 3.0	3.0 / 3.0 / 3.0	4.0 / 4.0 / 4.0	4.0 / 4.0 / 4.0	
FEED RATES	Rapids on X & Y & Z axis	m/min	20 / 20 / 20	20 / 20 / 20	20 / 20 / 20	20 / 20 / 20	20 / 20 / 20
	Max. cutting feedrate	m/min	10	10	10	10	10
TOOL MAGAZINE	Tool storage capacity	pcs	20 armless / 24 arm	20 armless / 24 arm	20 armless / 24 arm	20 armless / 24 arm(BT-40) 16 armless / 24 arm(BT-50)	20 armless / 24 arm(BT-40) 16 armless / 24 arm(BT-50)
	Type of tool (optional)	type	BT-40(CAT-40)	BT-40(CAT-40)	BT-40(CAT-40)	BT-40(CAT-40) BT-50(CAT-50)	BT-40(CAT-40) BT-50(CAT-50)
	Max. tool diameter	mm(inch)	100(4.0) armless 76(3.0) arm	100(4.0) armless 76(3.0) arm	100(4.0) armless 76(3.0) arm	100(4.0) armless 76(3.0) arm	100(4.0) armless 76(3.0) arm
	Max. tool weight	kg	7	7	7	7(BT-40) / 15(BT-50)	7(BT-40) / 15(BT-50)
	Max. tool length	mm(inch)	250(9.8) armless 300(11.8) arm	250(9.8) armless 300(11.8) arm	250(9.8) armless 300(11.8) arm	250(9.8) armless 300(11.8) arm	250(9.8) armless 300(11.8) arm
	AVG. CHANGING TIME (ARM)	Tool to tool	sec.	2.7	2.7	2.7	2.7(BT-40) / 3.8(BT-50)
Chip to chip (50% Z axis)		sec.	6.7	6.7	6.7	6.7(BT-40) / 11(BT-50)	6.7(BT-40) / 11(BT-50)
Air source required		kg/cm ²	6 up	6 up	6 up	6 up	6 up
ACCURACY	Positioning VDI 3341	mm(inch)	P 0.01 (0.0004)	P 0.01 (0.0004)	P 0.01 (0.0004)	P 0.01 (0.0004)	P 0.01 (0.0004)
	Repeatability VDI 3341	mm(inch)	Ps 0.006 (0.0003)	Ps 0.006 (0.0003)	Ps 0.006 (0.0003)	Ps 0.006 (0.0003)	Ps 0.006 (0.0003)
DIMENSION	Machine weight (Net)	kg	5,000 armless 5,400 arm	6,200 armless 6,700 arm	6,700 armless 7,000 arm	9,600 arm	1,000 arm
	Power source required	KVA	15	15	15	30	30
	Floor space (L x W x H)	mm(inch)	2,508 x 2,745 x 2,720 (98.8 x 108.1 x 107.1)	2,795 x 2,875 x 2,700 (110.1 x 113.2 x 106.3)	3,140 x 2,880 x 2,850 (123.7 x 113.4 x 112.2)	3,418 x 3,380 x 2,920(BT-40) (134.5 x 133 x 115.0) 3,418 x 3,380 x 3,030(BT-50) (134.5 x 133 x 119.3)	3,858 x 3,380 x 2,920(BT-40) (151.8 x 133 x 115.0) 3,858 x 3,380 x 3,030(BT-50) (151.8 x 133 x 119.3)
Shipment advice	-	1 x 40' HQ(3 sets)	1 x 40' HQ(2 sets)	1 x 40' HQ(2 sets)	1 x 40' HQ(1 set)	1 x 40' HQ(1 set)	

※ All specifications are subject to change without prior notice. ※ Machine colors shown in this catalog are for reference only. Correct colors are dependent on the actual machine.

STANDARD ACCESSORIES:

- Mitsubishi M70 controller
- Spindle speed 6,000 / 8,000 / 10,000 rpm (depend on machine model)
- Automatic tool changer
- Full splash guard
- Heat exchanger for electric cabinet
- Automatic lubricating system
- Spindle oil cooler
- Spindle air blast system (M code)
- Spindle air blow system
- Spindle orientation
- Coolant gun and air socket

- Leveling kits
- Removable manual & pulse generator (M.P.G.)
- LED light
- Rigid tapping
- Coolant system and tank
- Cycle finish indicator and alarm lights
- RS-232C interface with cable (10 m)
- Tool Box
- Operational and maintenance manual
- Transformer

OPTIONAL ACCESSORIES:

- Spindle speed 12,000 rpm (Belt type)
- Spindle speed 15,000 rpm (Direct drive)
- Coolant through spindle (CTS)
- Spindle coolant ring (M code)
- Controller (FANUC / SIEMENS / HEIDENHAIN)
- German ZF gear box
- Automatic tool length measuring device
- Automatic work piece measurement system
- Quick tool change (2 sec.)
- CNC rotary table and tailstock
- Oil skimmer
- Link/Screw type chip conveyor with chip bucket
- Linear scales (X/Y/Z axis)
- Coolant through tool holder